

YOUR TURN

QUESTION: I've broken the trunk key cylinder end that holds the shaft that turns the lock assy. What can I do? CLIFF, Canada

ANSWER: Most GM models '50-'58 cars use the same unit. '55-'57 door cylinders from Chevy are the same.

QUESTION: I need a carburetor cross shaft linkage that bolts to the engine - transmission spacer plate on my automatic F.I. Vette. GEORGE, Nebraska

ANSWER: '58-'62 will work. Also, the lower kick down rod. If you need to find another spacer plate because you have a broken one, any V8 car using a cast iron trans. will work.

QUESTION: I've added electric windows, but I'm missing the two metal channels that attach to the front of the door to protect the wires. I own a '62. Help! TOM, North Carolina

ANSWER: '55-'57 Chevy cars used the same ones that had power windows. Also, the motors are round like '56-'58 Vettes.

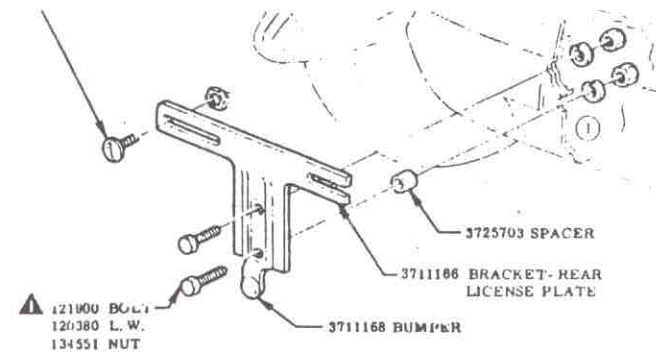
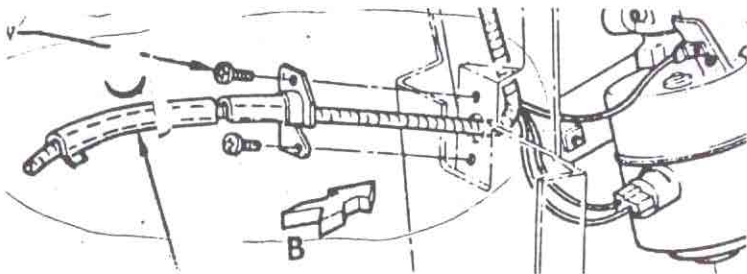

QUESTION: I need a rear license plate bracket original with the part number stamped on and would rather not use a repro that isn't. Can you advise?

ANSWER: Chevy cars that are the same year as Vettes will have what you're looking for, number and all.

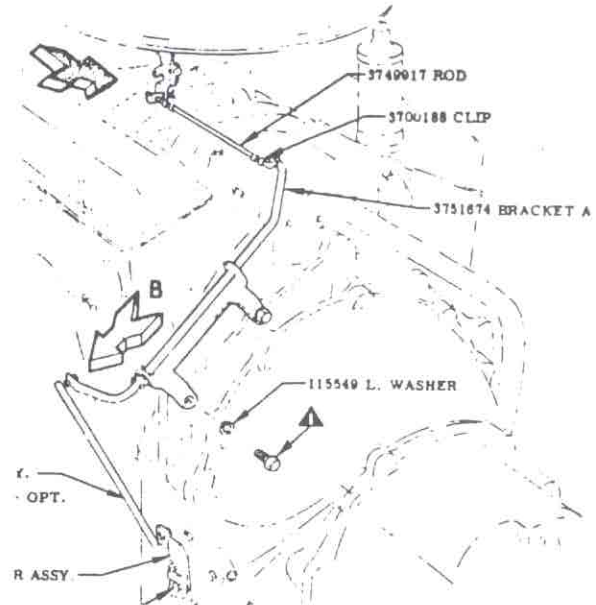
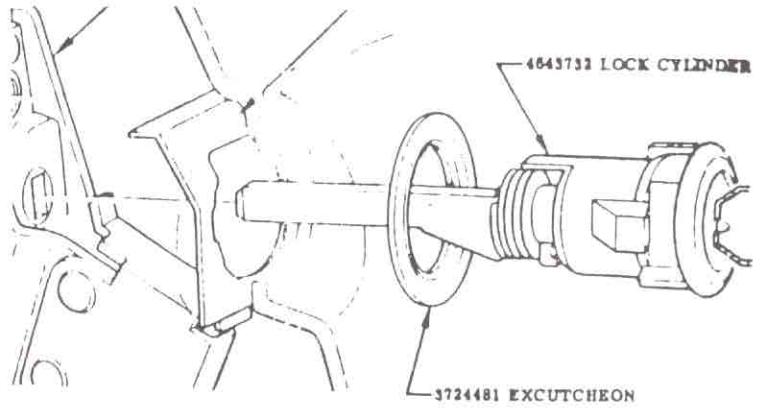
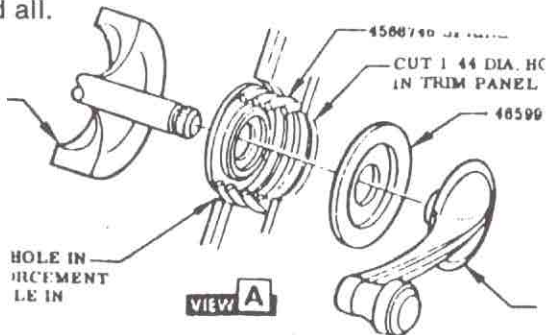

QUESTION: I need a master brake filler cap. What car used the same plug? Tennessee

ANSWER: '50's Olds, Caddy, Chevy and GM.

QUESTION: Did any other model have the same window crank handles as a '58 Vette?

ANSWER: 3725377 handle is still available from GM.

QUESTION: What can be substituted for the natural safety switch on a '58 automatic shifter linkage?

ANSWER: Buy the 4 sp. back-up light switch from GM or parts house. Works good!

