

## 1955 OIL PAN

Locating a 33 year old oil pan in good or NOS condition is not easy. I was lucky locating one through N.C.R.S. Driveline. When I called about his NOS pan still in the box, I felt good talking to a man that knew the difference, and I was more than ready to pay the price. Then I thought, this would be a good article for 55 vette owners.

Many people advertise, one pan fits all. Not true for the 55. The 55 engine was the only V8 engine that never had an oil filter casting in the block (car or vette). Cars did offer a dealer add-on that was located on the thermostat housing on top of the engine, but vette had no option offered. So, it's easy to understand that if the engine bottom was cast without a filter, then the oil pan must have been different. When looking for a 55 pan, look at the rear area where the gasket fits. The curved left side is the same as the curved right side. All other oil pans will be more of a straight line on the left side then curve off of the right side.

NOS 55

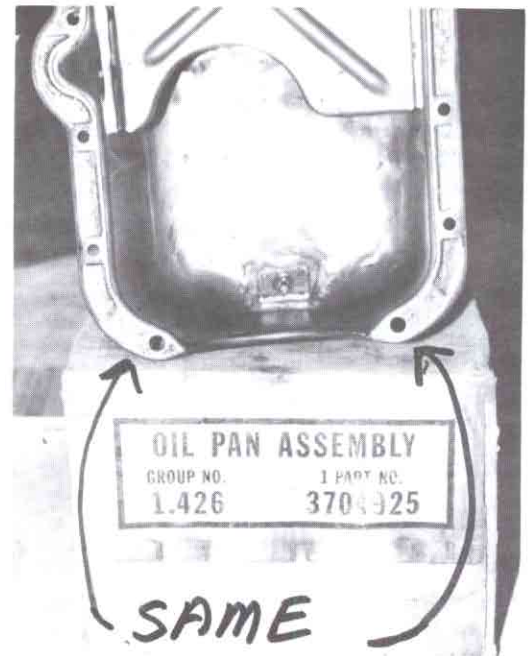

1956

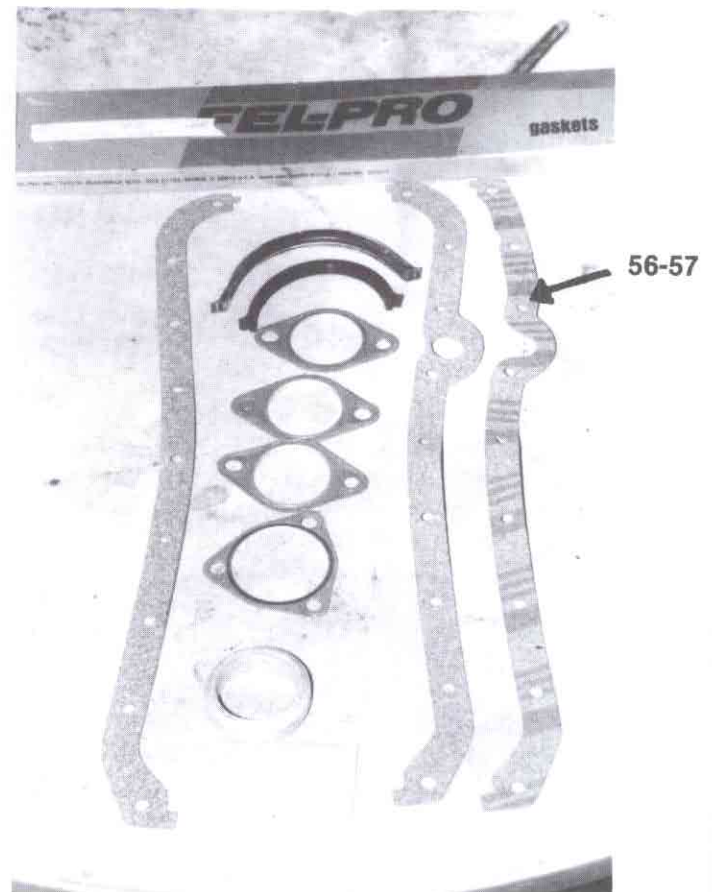
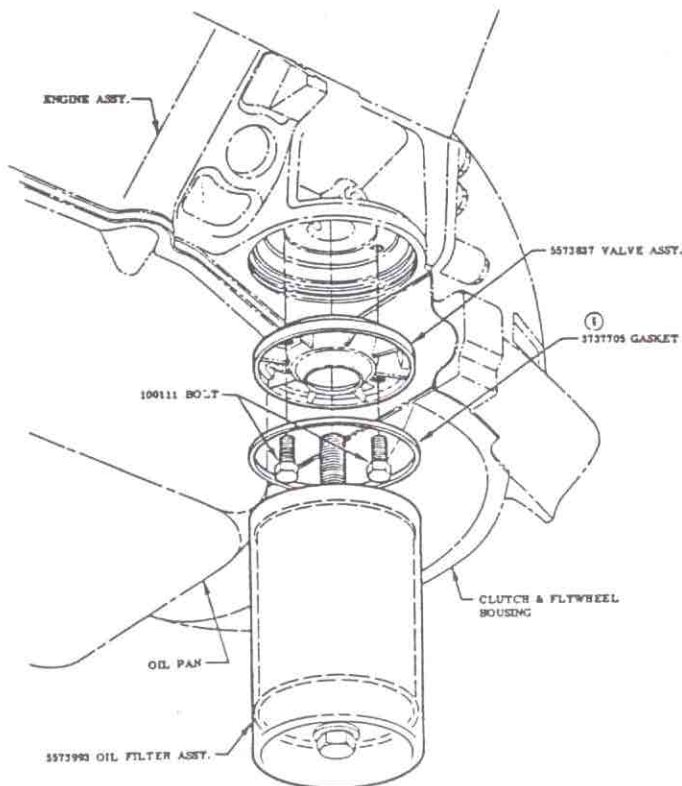

OS5197C-3

FEL-PRO GASKETS COME WITH EXHAUST GASKETS, PAN, SEAL, DONUT AND DRAIN PLUG PLASTIC WASHER. JUST LIKE IN THE OLD DAYS FOR 55-56 CARS.