

Corvette Central

In their new parts book it shows a new rubber clove box door bumper you can order. G.M.... #3725720 and can be seen in the assembly manual. This is a part not well known to many owners and was used from 56-62. It will keep your clove box from rattling.

Seat Brackets

In the last issue, I Wrote about the seat brackets. When I received the new Paragon book in the mail I was surprised to see that they the underbody seatbelt reinforcement bracket.

This is the one that goes at the center area. They also call out the two types that I wrote about, having either the bolt spot welded in or with out the bolt. Price is \$20.00 each. Also they . The lower Soft and Hard Top Handles seatbelt anchor bracket, 4 per vette, at \$20.00 each, and they seem correct.

Most stuff, that I have seen Paragon has been good and correct, but some stuff is called out incorrect too. Their number is 1-800-882-4688 Editor Seat Belt Instructions Sheet was first printed in the NCRS Restorer-Volume 5, Number 4, Spring of 1979. NOTE- also that there has been talk over where the handles were located. By the print it shows them installed at the center area, but on the other hand, most if not all vettes (no one knows for sure) were installed at the Dealer, and the person doing the installation, could have put the handle out board, do to the fact that most cars had the handle out board. If someone else would like to take up this argument, please do!

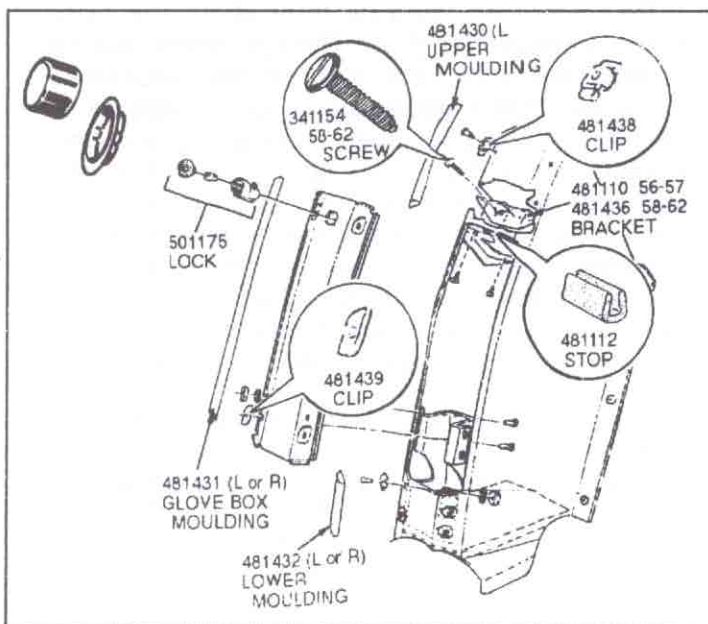

Positracion Rear-Axle

NCRS Volume 18, Number 3, Winter 1992, has a great article on Servicing the Positraction Rear-Axle Unit. This was a booklet sent out to the service department of dealers on how to service and installing a It covers the field installation of a posi into a 55-57 car or 56-57 Corvette.

It mentions that on early 57 production models you have to grind down the reinforcing ribs inside the carrier, to allow clearance for the Posi-unit. It also mentions cutting off .140" from each axle on 56 vette or 55 car to clear the spider gear shaft so that it doesn't touch, and it says to replace the 57 axle with a #3743035-6 axle because of the change at the outer end, having a different shape. This is the reason early posi 57's didn't have the large (P) on the case, as the later posi did. But the thing to understand is! That you could find a posi-unit also in a 56, because an owner could return to the dealer to have one installed do to the later service manual installation. (It would seem that the carrier would be the same as 57, with maybe a restamp over the old one). Calling out the fact that it is now a posi? Early 57 did call out posi where there is no large P on the case.

Soft top Hard top Handles

I have added a better pictures to show what to look for when determining weather you have the right handle for each application. Fig. 1 shows the bottom side of each handle, for hard or soft top.

As you can see the two are different as seen here. Fig. 2 shows clearly the round type and tapered type. (Remember, 56-67 are constructed the same, but for having either a short handle or long handle).

Cover Picture

53-55 Soft Top Mohair Flap -the picture was upside down, hope not many 53-55 owners were going crazy trying to understand what they were looking at?.

Elbow

Volume 6, Number 2 I wrote about the fuel pump ELBOW and said that Corvette Central sells them as #351416, I was later told that they are a replacement part four sided ,and not correct as original, six sided.