

Routing of windshield washer hoses on all carbureted models.

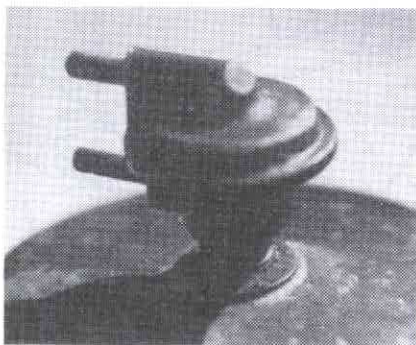

Left: Washer vacuum canister head.

Below: Aspect illustrations of canister mounting bracket to vacuum head: (Far left) vacuum canister #3752343 for 1958-61 dual 4-bbl. & FI (and very early '62 FI); (center below) canister #3741901 for 1958-1961 (to about 4/25/61) for single four-bbl. applications; (below right) canister #3814232 (with studs) for 1961 (from about 4/25/61) single 4-bbl., and all 1962's (except very early FI).

#3752343

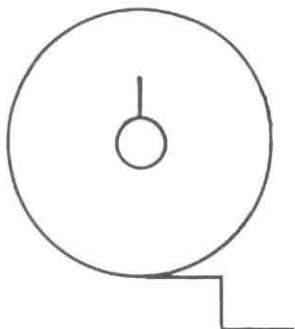

#3741901

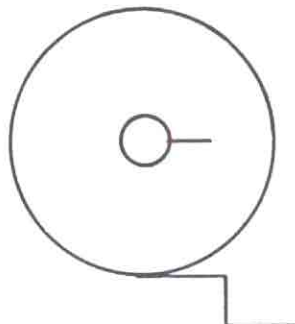

#3814232 (w/studs)

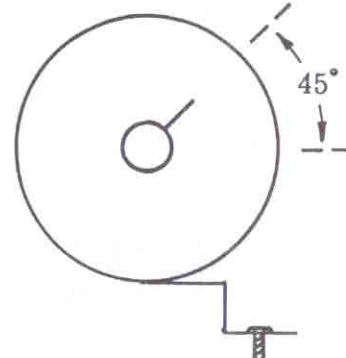

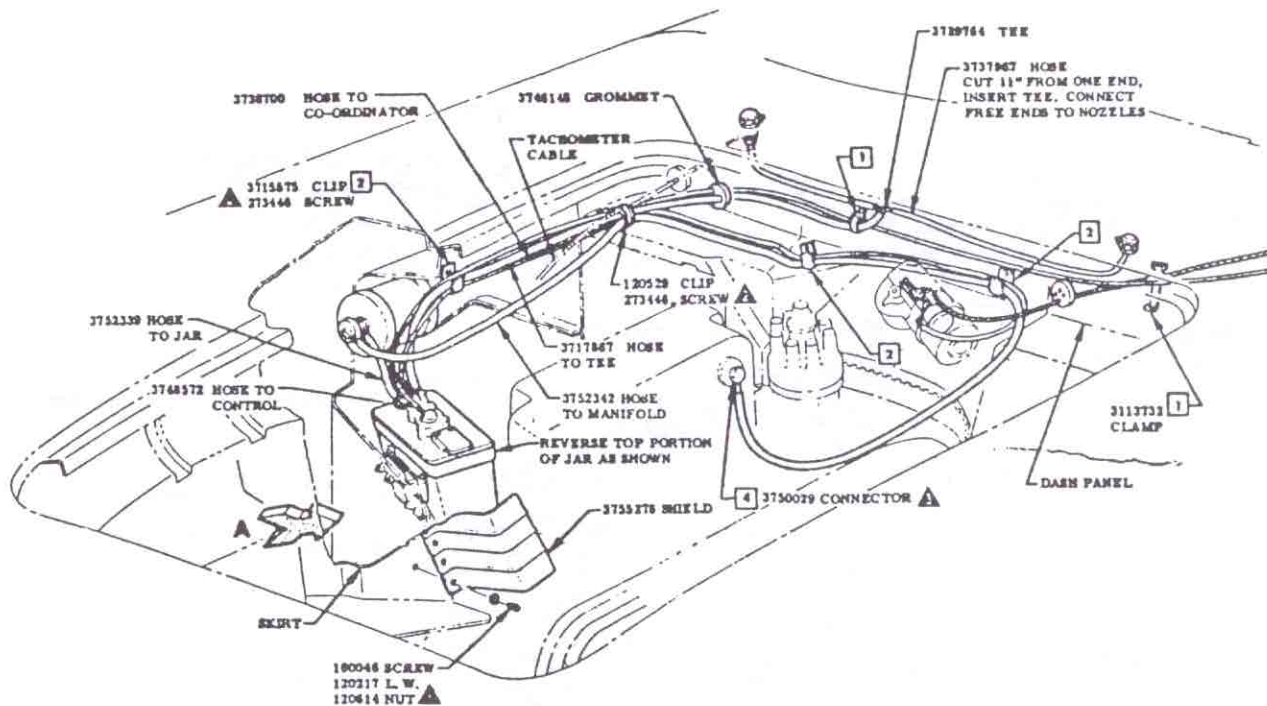

Windshield washer hose routing on 1961 FI models.

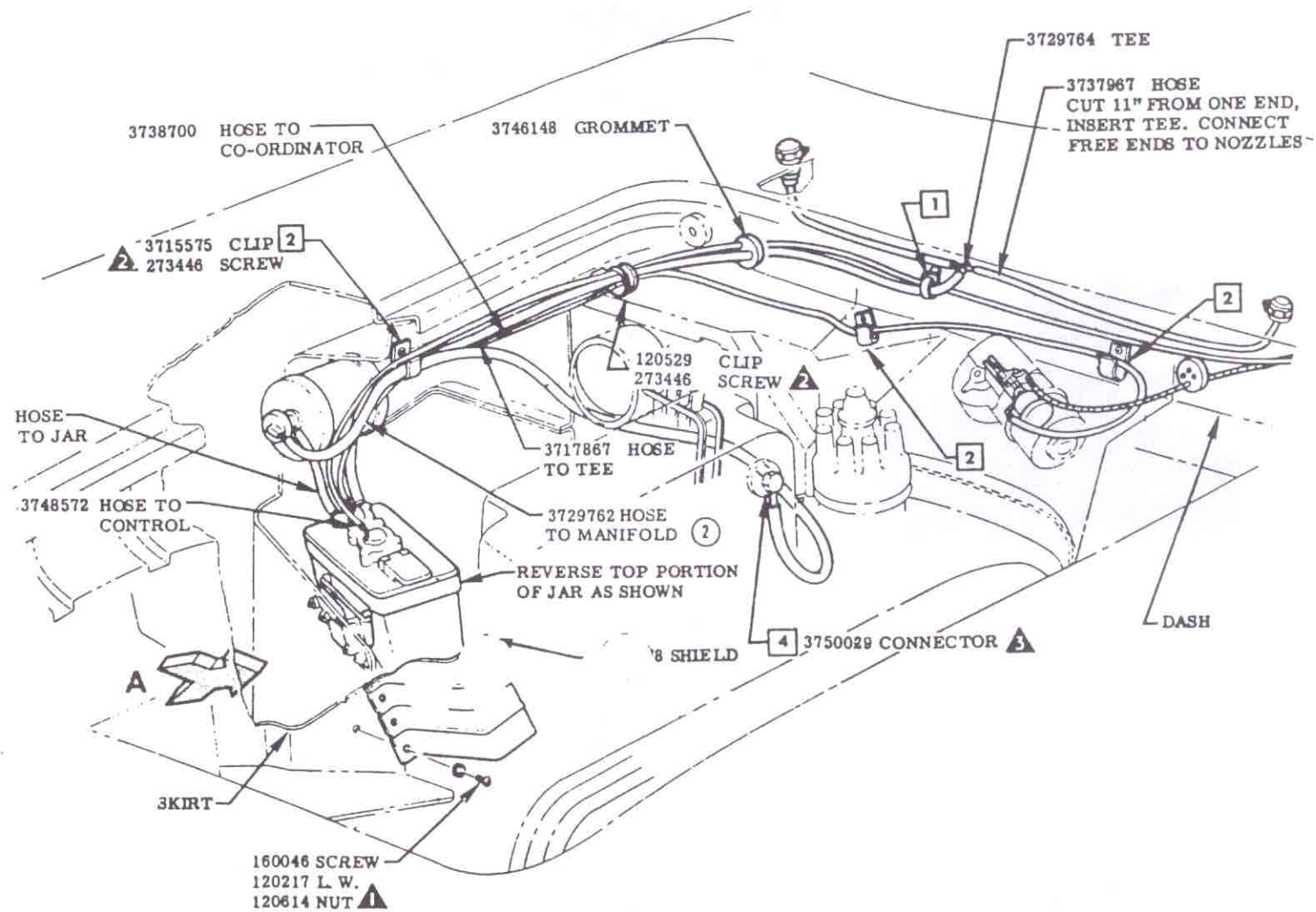

Windshield washer hose routing on 1962 FI models.